

TUPELO ST 16

LOT 28

DPS 36453

BP 38301



38301
HAMILTON CITY COUNCIL

APPLICATION FOR A BUILDING PERMIT

Office of the Chief Building Inspector
Private Bag
Gardens Place, Hamilton, N.Z.
Phone: 386 677



To erect/alter/demolish/install a PRIVATE DWELLING

stem,
e and

APPLICANT TO COMPLETE — PLEASE PRINT IN INK

Address of Project 16 Tupelo BAZZET
 Lot No. 28 DPS 36453 Area 1088
 Val. No. _____ Ward _____
 Name of Owner CENTRAL HOME BUILDERS
 Address 19 RIDGEWAY PLACE HAM
 Signature [Signature]
 Area of ground floor 81.5
 Area of other floors _____
 Total floor areas _____
 Total number of floors _____
 Floor area of other buildings _____
 Soil Type (eg. clay, peat etc.) CLAY

Proposed use PRIVATE
 Name of Builder CENTRAL HOME BUILDERS
 Address _____
 Signature _____
 Contact Phone No. 438420
 Name of Engineer _____
 Address _____
 Name of Designer _____

COSTS	\$	¢
Building (Labour & materials)	41500	=
Plumbing and Drainage (Labour Only)	1500	=
Total Cost	43000	=

rents.
es on

vings.
isting

owing

OFFICE USE ONLY

Fees	\$	¢
Building	187	-
Plumbing and Drainage	114	-
Crossing	-	-
Research Levy	43	-
Stormwater Levy	-	-
Footpath Deposit	100	-
Reserves Contribution	-	-
Photocopying	-	-
Total \$ Inc. G.S.T.	444	-

TO STRUCTURAL		
TO HFS		
Engineers Supervision		
Design Cert		

ISSUE PERMIT	<u>Yes</u>
DATE	<u>9-9-87</u>
Sign	<u>[Signature]</u>

Date Permit	<u>10/9/87</u>
Permit No.	<u>38301</u>
Receipt No.	<u>059406</u>

icture

ed for
nsure

le the

tion.

ools.

HAMILTON CITY COUNCIL



STATUTORY PLANNING
BUILDING AND HEALTH
DEPARTMENT

9 September 1987

DUTY INSPECTOR AVAILABLE - 9am - 12 noon.
PHONE: 38-6677

Municipal Offices
Garden Place
Private Bag
Hamilton, New Zealand
Phone (071) 386-699

MR Central Home Builders
19 Ridgeway Place
HAMILTON

TAX INVOICE

GST No 11-174-531
Tax Invoice only if accompanied
by an official receipt.

Dear Sir/Madam,

re: Dwelling Lot No. 28 D.P.S. 36453
Address 16 Tupelo Street

In reference to the above application I advise that this has now been approved, and upon receipt of the fees and charges itemised below, a Building Permit will be issued.

FEES ARE TO BE PAID TO CASHIERS PRIOR TO UPLIFTING BUILDING PERMIT FROM THE PERMIT AND LICENCE CENTRE.

Approved documents are to be on site at time of inspection.

Yours faithfully,

CHIEF BUILDING INSPECTOR.

Per:

Building Fee	HB 0202-99-922	\$...187...00
		114. 00
Plumbing & Drainage	HB 2202-99-932	\$.....
Crossing	ZR 0149-99-922	\$.....
Research Levy	AT 3202-00-924	\$...43. 00
Stormwater Levy	YP 0202-99-959	\$.....
Footpath Deposit	AT 3702-00-813	\$...100...00
Reserves Contribution	AR 3620-00-988	\$.....
Photocopying	HB 0202-99-995	\$.....
Signs & Hoardings	HB 0202-99-962	\$.....
Total Incl. G.S.T.		\$...444...00

CONDITIONS:

1. Foundation inspection to be called for.
2. Pre-lining inspection to be called for.
3. Sewer connection to be exposed at foundation inspection.
4. Boundary pegs to be shown at footing inspection.
5. All drainage and plumbing to comply with Drainage & Plumbing Regulations 1978 and H.C.C. Bylaws.
6. Stormwater to be disposed of in an approved manner by Licensed Drainlayer and drainage permit uplifted.
7. Gully traps to be at least 75mm above finished outside ground level and at least 75mm below finished internal floor level.
8. The whole of the required parking or loading spaces, access drives and aisles and manoeuvring spaces shall be formed and thereafter maintained in an all-weather dust free surface to the Council's satisfaction.

BUILDING PERMIT ACTION SHEET

ADDRESS 16 Tupelo St OWNER Central Home Builders
 LOT 28 D.P.S. 36453 USE PROPOSED Dwg
 T.P.O. FILE..... T.C. FILE..... LOG SHEET K13

Health		24/87 <i>[Signature]</i>
Streets	Crossing required — Yes / No If yes, is street kerbed — Yes / No Distance — Kerb to Kerb <input type="checkbox"/> Vertical Footpath <input checked="" type="checkbox"/> Concrete <input type="checkbox"/> Seal Size required..... metres Property Boundary Type <input type="checkbox"/> Mountable Type <input type="checkbox"/> Metal <input type="checkbox"/> Other Is street correctly formed at boundary — Yes / No metres	21/9
Town Planning	Zoning <u>Residential 1</u> Condition <u>41 Applies</u>	MS 29-87
Water Supply		<i>[Signature]</i> 2/9/87
Plumbing and Drainage	100 101 111	<i>[Signature]</i> 29-87
Drainage		<i>[Signature]</i> 2/9/87
Building	<p><u>Uttfield 3/9/87</u></p> <ol style="list-style-type: none"> 1/ Show opening window sashes on elevations 2/ Confirm that subfloor details shown on sub-floor drawing than supersede standard details 3/ Deck and landing details required to correct ground profiles. Encasements required where decks exceed 1.0 metre above ground level. <p><u>Conditions</u></p> <ol style="list-style-type: none"> 1/ i 2/ ii 3/ sewer connection to be exposed at foundation inspection 4/ iv 	

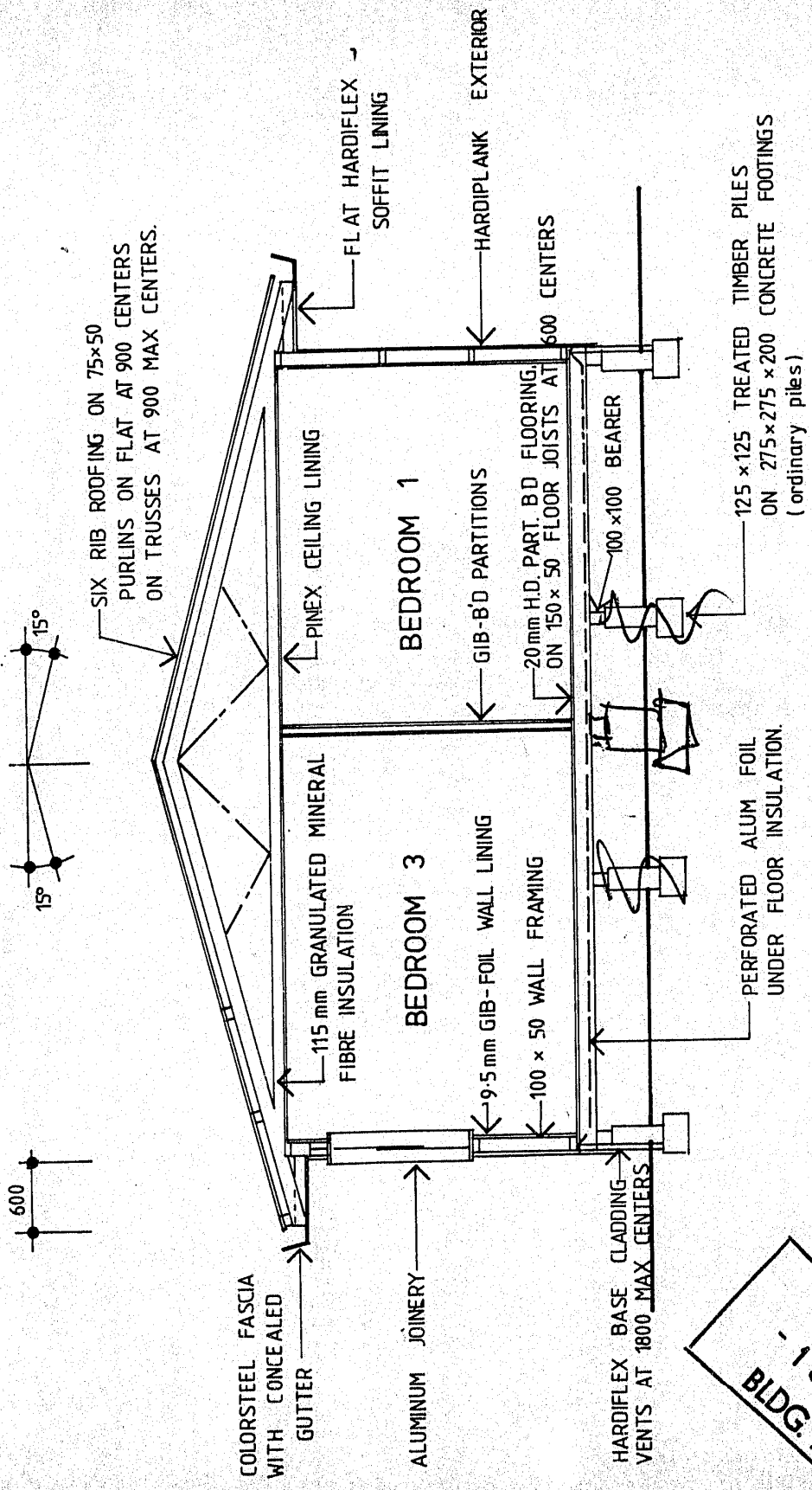

CROSS SECTION A A
 scale 1 : 50

RECEIVED
 - 1 SEP 1987
 BLDG. DIV.

Six Rib Iron Roofing

Colorsteel Fascia with concealed gutters

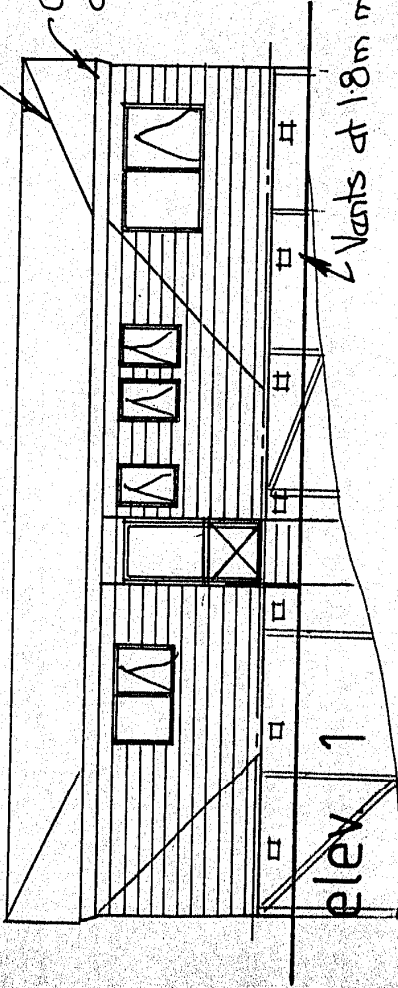

Vents at 1.8m max crs.

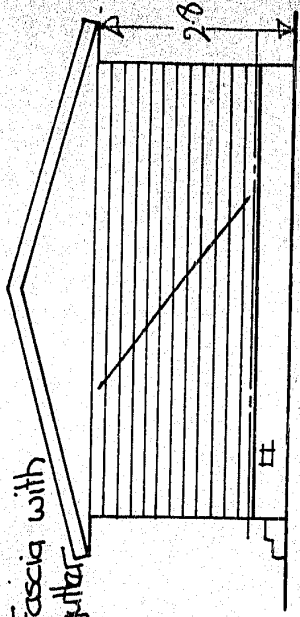

elev. 2

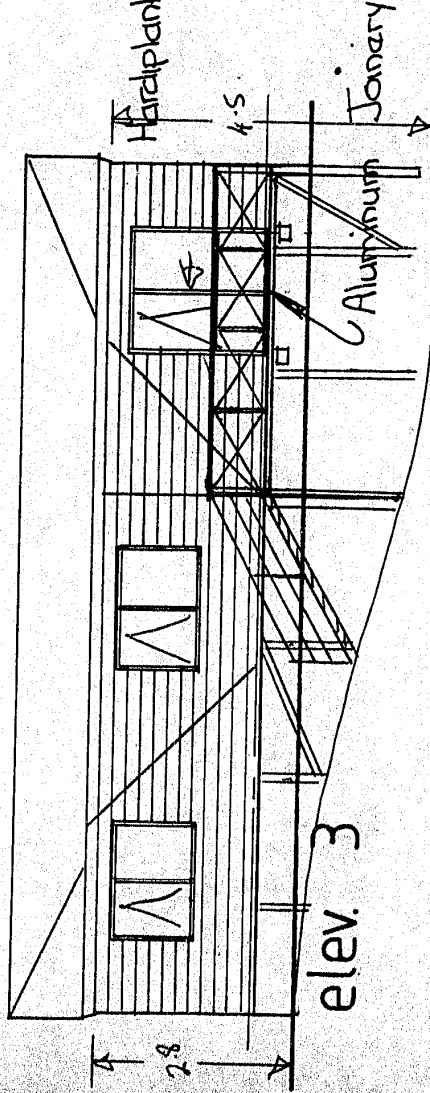

elev. 3

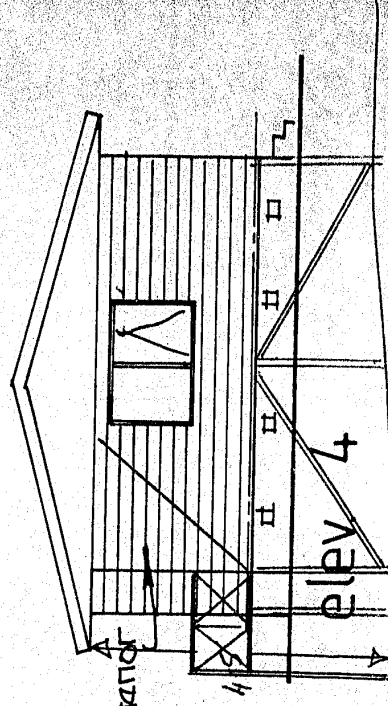

elev. 4

ELEVATIONS.
scale 1 : 100

RECEIVED
- 1 SEP 1987
BLDG. DIV.

BRANZ

SHEET A

(CIRCLE whichever is applicable)

NAME: HARROW

ADDRESS:

STOREY: Single or Uppermost
Lower of two or middle of three
Lower of three

ROOF TYPE: Light / Heavy

ROOF PITCH: 0° - 25°

WIND AREA: High / Medium / Low

W = 20 B.U.'s/m

EARTHQUAKE ZONE: A / B / C

E = 2 B.U.'s/m²

ROOF OR BUILDING LENGTH

BL = 12.6 m

ROOF OR BUILDING WIDTH

BW = 7.9 m

GROSS ROOF OR BUILDING PLAN AREA

GPA = 99.5 m²

EARTHQUAKE: B.U.'s ALONG AND ACROSS

E x GPA = = 199 B.U.'s

WIND: B.U.'s ALONG

W x BW = = 158 B.U.'s

WIND: B.U.'s ACROSS

W x BL = = 252 B.U.'s

SKETCH PLAN (external and internal walls) :

RECEIVED
- 1 SEP 1987
BLDG. DIV.

SHEET B

1 Total B.U.'s Required	2 Wall Line		3 Wall Bracing Elements Provided						
	Label	Minimum B.U.'s Required	Label No.	Type	Rating B.U.'s/m	Length (m)	B.U.'s Provided		
ALONG	A		1	1	42	2.0	84.0		
			2	1	42	2.4	100.8		
			126					Sub-total	184.8
	B		3	TOWER	72	1.2	72.0		
			70					Sub-total	72.0
	C		4	1	42	2.4	100.8		
			5	1	42	1.4 x 1.5	88.2		
			126					Sub-total	189.0
	D								
								Sub-total	
	199	TOTAL	322	TOTAL			445.8		

ACROSS	L		6	1	42	2.4	100.8		
			61					Sub-total	100.8
	M		7	TOWER	72	1.2	72.0		
			70					Sub-total	72.0
	N		8	TOWER	72	1.2	72.0		
			70					Sub-total	72.0
	O		9	1	42	2.4	100.8		
			67					Sub-total	100.8
	P								
								Sub-total	
252	TOTAL	268	TOTAL			345.6			

TUPERO STREET
MAN HOLE
1600 DEEP

RECEIVED
- 1 SEP 1987
BLDG. DIV.

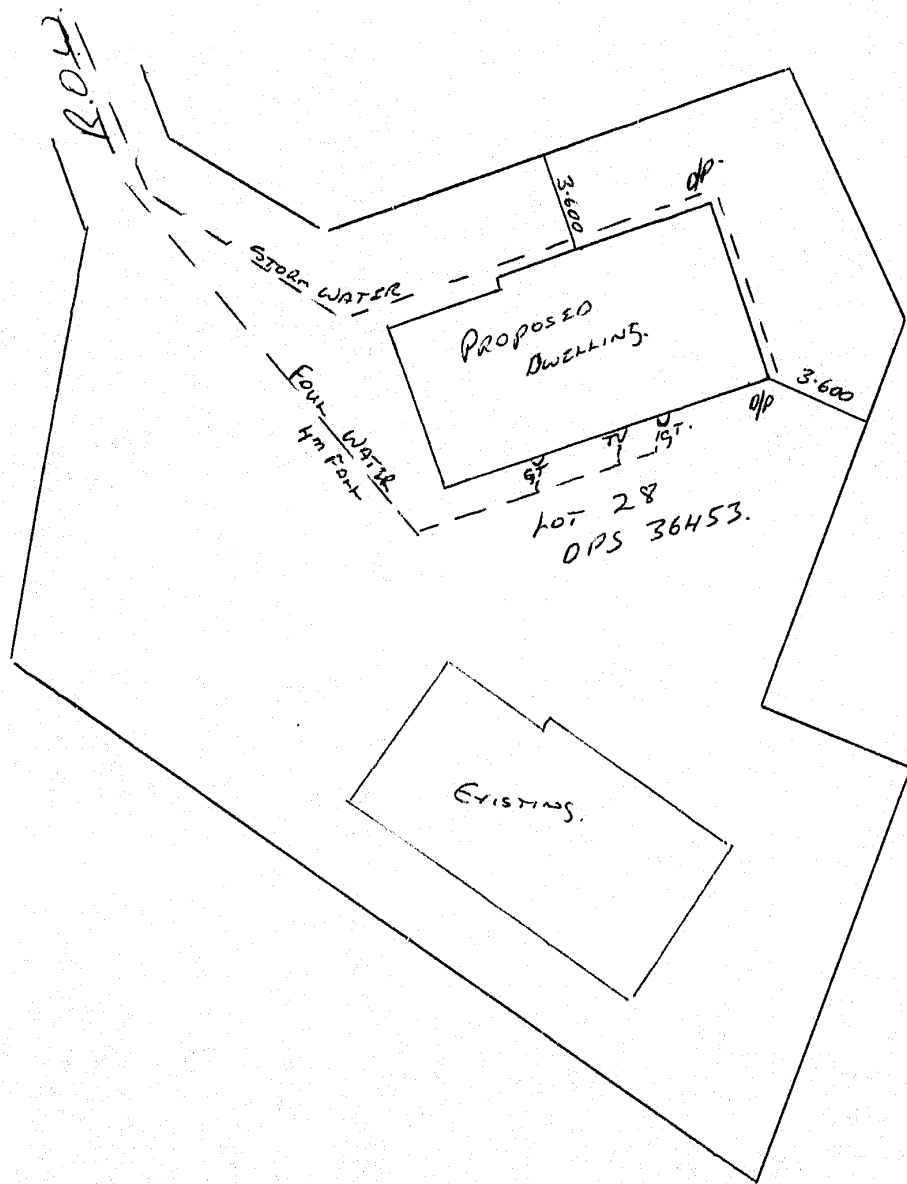

EXISTING

PROPOSED DWELLING

LOT 28
OPS 36453

STOR. WATER

FOUL WATER
4m FATH

R.O.W.

3.600

3.600

TV SET

op

op

op

TUPELO ST

16

LOT 28

DPS 36453

BP 38301

BUILDING CONTROL DIVISION
PROGRESS CARD

A 38420

ADDRESS 16 Tupelo St OWNER: Central Home Build BUILDER Owners

BUILDING PERMIT No. 38301 Lot 28 DPS 36453 Value 36453 Nature Unit

Date Issued: 10/9/87 Issue Notice: 1-9 SEP 1987

Withheld Notice 18 SEP 1987

TO STRUCTURAL FROM: TYPIST 4 SEP 1987

TO HES FROM: 9 SEP 1987

RECEIVED
 Date Received 1 SEP 1987
 BLDG. DIV.

AMENDED PLANS
 DATE
 Stat P.
 P. & D.
 Building
 Design

RECEIVING OFFICER COMMENTS

BUILDING

INSPECTIONS	SIGN	DATE	APP.	DATE
F'dation-Siting Concrete Floor Bond Beam Reinf.	<i>[Signature]</i>	15-9-87	✓	
Prelining	<i>[Signature]</i>	6-10-87	✓	
Completion	<i>[Signature]</i>	17-11-87	✓	

Ceiling insulation to be fitted, and two sub-floor braces to be fitted.
PM 6-10-87

DRAINLAYER R. Allen
 PLUMBER M. Tinkler

DRAINAGE PERMIT NO.	DATE
<u>028604</u>	<u>20-10-87</u> <u>20-4-88</u>
<u>028517</u>	<u>16-10-87</u> <u>16-4-88</u>

RECEIPT NO. BP 38301

NATURE OF WORK: New Unit

INSPECTIONS	SIGN	DATE	APP.	DATE
F'dation-Siting Concrete Floor Prelining Waste & Soil Pipe Foulwater Stormwater Completion	<i>[Signature]</i>	19/11/87	✓	
